

AL 22 AND AL 22M

USER'S MANUAL



WARNING: READ THE INSTRUCTIONS AND SAFETY PRECAUTIONS
IN THIS MANUAL CAREFULLY BEFORE USING THE FIREARM.

RIA
IMPORTS

ROCK ISLAND ARMORY

OWNER/USER'S MANUAL
AL22 & AL22M REVOLVER
RIA STEEL/STAINLESS STEEL

OPERATING INSTRUCTIONS MANUAL



As a responsible owner of this firearm, you must read the instructions and warnings in this manual carefully. Before using this firearm, make sure you understand thoroughly the contents of this manual.

This manual must always be in the firearm's carrying case whenever the owner/user brings it or when it transfers ownership. A copy of this manual is available upon request from:

ARMSCOR PRECISION INTERNATIONAL
150 N Smart Way, Pahrump NV 89060
E-mail: support@armscor.com

TABLE OF CONTENTS

1 Statement of Liability

1 State-By-State Warnings

2 Safety Precautions

HEALTH & SAFETY

4 Description of The Revolver

4 Basic Parts

6 Tech Specs

7 Exploded Views

ABOUT THE FIREARM

Ammunition 8

Operating Instructions 9

Cleaning The Gun 10

Revolver Maintenance 11

Storage and Transportation 12

Ordering Parts 13

Warranty 14

Notes 15

MAINTENANCE

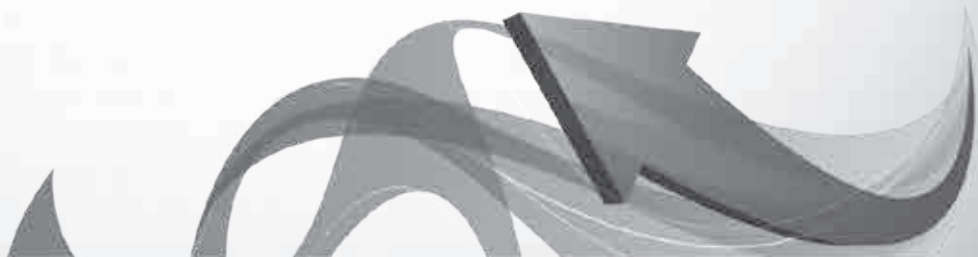

01 | STATEMENT OF LIABILITY

STATEMENT OF LIABILITY

This revolver is classified as a firearm or dangerous weapon. It is expressly understood that we assume no liability for its resale or unsafe handling under local laws and regulations. Armscor assumes no responsibility for physical injury or property damage resulting from either intentional or accidental discharge, or for the function of the firearm subjected to influence beyond their control. Armscor will honor no claims which may result from careless handling, unauthorized adjustments, defective or improper ammunition, corrosion or neglect. Examine your firearm carefully at the time of purchase. It should be forwarded immediately to the factory or its sales agent if any adjustment of any kind is required.

State-By-State Warnings



CALIFORNIA STATE WARNING

CHILDREN ARE ATTRACTED TO AND CAN OPERATE FIREARMS THAT CAN CAUSE SEVERE INJURIES OR DEATH. PREVENT CHILD ACCESS BY ALWAYS KEEPING FIREARMS LOCKED AWAY AND UNLOADED WHEN NOT IN USE. IF YOU KEEP A LOADED FIREARM WHERE A CHILD OBTAINS AND IMPROPERLY USES IT, YOU MAY BE FINED OR SENT TO PRISON. IT IS UNLAWFUL TO USE A MAGAZINE WITH A CAPACITY OVER 10 ROUNDS.



MASSACHUSETTS STATE WARNING

IT IS UNLAWFUL TO CARRY ANY MAGAZINE OR BELT WHICH HOLDS MORE THAN TEN ROUNDS, UNLESS AUTHORITY IS GRANTED BY THE BOSTON POLICE COMMISSIONER. IT IS UNLAWFUL TO STORE OR KEEP A FIREARM, RIFLE, SHOTGUN OR MACHINE GUN IN ANY PLACE UNLESS THAT WEAPON IS EQUIPPED WITH A TAMPER RESISTANT SAFETY DEVICE OR IS STORED OR KEPT IN A SECURELY LOCKED CONTAINER.



NEW YORK STATE WARNING

IT IS UNLAWFUL TO CARRY ANY MAGAZINE OR BELT WHICH HOLDS MORE THAN SEVEN ROUNDS, UNLESS AUTHORITY IS GRANTED BY THE STATE OF NEW YORK. THE USE OF A LOCKING DEVICE OR SAFETY LOCK IS ONLY ONE ASPECT OF RESPONSIBLE FIREARMS STORAGE FOR INCREASED SAFETY, FIREARMS SHOULD BE STORED UNLOADED AND LOCKED IN A LOCATION THAT IS BOTH SEPARATED FROM THEIR AMMUNITION AND INACCESSIBLE TO CHILDREN AND OTHER UNAUTHORIZED PERSONS.

02 | SAFETY PRECAUTIONS

Safety must be the first and constant consideration of every person who handles firearms and ammunition. The person with a firearm in his possession has an important responsibility. He/she must know how to use his/her firearm safely:

The AL 3.0/AL 3.1 Stainless Steel REVOLVERS are one of the safest type handguns, as long as it is used correctly by a competent person. Following are basic safety precautions which the user must be thoroughly familiar with when handling the revolver.

1. Always keep the firearm holstered except when drawn for a definite purpose.
2. Always check the firearm for live ammunition when picked up, drawn from the holster, handed to, or received from another person.
3. Never point the firearm at anything you do not intend to shoot.
4. Never cock the hammer of the firearm unless you are ready to immediately shoot it. Do not even insert your finger in the trigger guard until you are ready to shoot.
5. Avoid dry firing even with dummy cartridges, unless the same is performed on a regular target range or at a known inanimate target.
6. When holding the firearm that is ready to fire, be absolutely certain that it is not pointed at any part of your body or at any person within your immediate vicinity.
7. Beware of obstructions in the barrel. If, when firing, a weak or peculiar report is heard, cease firing and inspect the barrel for an obstruction. Remove stuck bullet, if any. Then check to insure there is no obstruction in barrel or chamber.
8. When a misfire or a "dud" is experienced, keep the revolver pointed at the target for at least ten seconds before inspecting the firearm; a delayed firing may occur.
9. Open the cylinder and immediately eject all cartridges.
10. When possible, wear shooting glasses and hearing protectors when firing.
11. Do not shoot at a hard surface, or water for the bullet can glance off and travel in unpredictable directions with considerable velocity.
12. Avoid drinking alcoholic beverages when handling the firearm.

WARNING:

DO NOT ATTEMPT TO USE ANY FIREARM WITHOUT HAVING A COMPLETE UNDERSTANDING OF ITS PARTICULAR CHARACTERISTICS AND SAFE USE.

WARNING:

YOU SHOULD NEVER DEPEND ON A SAFETY MECHANISM OR ANY OTHER MECHANICAL DEVICE TO JUSTIFY CARELESS AND IMPROPER HANDLING.

WARNING:

THIS FIREARM WAS MANUFACTURED TO PERFORM PROPERLY WITH THE ORIGINAL PARTS AS DESIGNED. PLEASE MAKE SURE ANY PARTS YOU BUY ARE INSTALLED CORRECTLY AND THAT NEITHER REPLACEMENTS NOR ORIGINALS ARE ALTERED OR CHANGED. PUTTING A FIREARM TOGETHER INCORRECTLY OR WITH MODIFIED PARTS CAN RESULT IN DAMAGED FIREARM, DANGER, AND INJURY OR DEATH. ANY MODIFICATIONS TO FIREARM WILL VOID FACTORY WARRANTY.

03 | SAFETY PRECAUTIONS

The revolver has been designed so as to ensure its fully reliable function without any hazard for the user, provided these instructions are fulfilled. Please, take into account that the safe use of the revolver does not depend only upon its flawless mechanical functioning, but also upon personal responsibility of the user and his observing of all security principles. Every weapon can be dangerous for the user or other persons within shooting distance, if handled irresponsibly! The following security principles shall be kept to make the operation safe:

The following security principles shall be kept to make the operation safe:

1. Learn the operation of the revolver prior to starting its use.
2. Make sure the weapon is not loaded prior to handling it.
3. The revolver is intended for shooting in the temperature range 14 F through 122 F.
4. Except for self-defense always keep the gun pointed to an area where no person can be endangered.
5. Check the bore of the barrel prior to shooting – whether it is clean and free of obstructions.
6. Make always sure that the target and its surrounding areas are able to receive the impact from the shots. Verify the conditions of the place and the safety of persons in its vicinity before starting to shoot. Water and very hard surfaces can cause the projectile to ricochet.
7. Always use the specified original ammunition of the caliber marked at the barrel.
8. Do not use old, dirty, damaged or re-loaded ammunition.
9. Never leave a loaded revolver without supervision.
10. Hold the revolver at the grip with your finger away of the trigger. Put the forefinger on the trigger only before the intended shot.
11. Only carry your gun with released striking mechanism. Do not carry your revolver in your pocket or behind your belt. Use a suitable belt-type or underarm gun holster.
12. Shooting any revolver is accompanied with lateral gas spray containing lead and carbon particles escaping with high velocity to the sides through the gap between the cylinder and the barrel. Hold the weapon in front of you and make sure no gas can hit persons in your vicinity.
13. Use safety glasses and ear protectors while shooting.
14. In case your shot fails, keep the gun pointed to the target for a few seconds. In such cases there may be the possibility of delayed cartridge detonation. If no shot comes out after this interval, open the cylinder and check whether there is a trace of the firing pin on the primer. If so, the ammunition seems to be defective, if not, the firing pin or the striking mechanism is likely to be the problem.
15. After a weak or suspicious shot unload the revolver and check the bore of the barrel for problems (the shot may be seizing).
16. Never use a revolver with functional failure.
17. Any defective part shall be replaced with an original part only. Exclusively a specialized gunsmith or repair shop or the manufacturer may carry out the repair.
18. No mechanical amendments of the weapon are admissible.
19. Keep the revolver clean. Impurities, dust and grease can cause the failure.
20. Before and during the shooting abstain from alcohol, drugs, and unsuitable pharmaceuticals.
21. When storing the revolver, or prior to cleaning or transporting it, make sure that all cartridge chambers are empty.
22. Keep the weapon and the ammunition always separated, in a dry, safe and locked place, away from children's and unauthorized persons' reach.

"We suggest you to participate in a shooting, safety, and self-defence qualifying course for best performance and for full safety when operating the weapon."

WARNING:

THE MANUFACTURER IS BY NO MEANS LIABLE OR OBLIGED TO INDEMNIFY ANY DAMAGE THAT HAS OCCURRED DUE TO INAPPROPRIATE HANDLING OF A REVOLVER. THE USER IS RESPONSIBLE FOR ANY DAMAGE OR INJURY IN SUCH CASE.

04 | DESCRIPTION OF THE REVOLVER

The revolver consists of a frame wherein a barrel is firmly screwed inside the shroud of the barrel and wherein the indexing mechanism of the cylinder, as well as the triggering and striking mechanisms are accommodated. The cylinder (having a central cartridge extractor) is pivoted on a crane. Front sight is a part of the barrel shroud; the frame carries a fixed or adjustable rear sight. The handle of the revolver is provided with screwed grip plates that are exchangeable (to suit the customer's wish).

The frame, shroud and cylinder are made of steel or stainless steel, according to model marking. The revolver is single- and double-action type. Pulling the trigger while double-action, the hammer gets cocked, at the same time the cylinder is indexed by one cartridge chamber and, at the last phase of the trigger movement, the cock is released, and a shot takes place. The hammer can also be cocked by hand (single action) and the shot takes place when the trigger is actuated, overcoming a smaller resistance of the trigger than in a double action mode.

1. Front Sight
2. Barrel Shroud with Barrel
3. Cylinder
4. Rear Sight
5. Hammer
6. Thumb Piece
7. Grips
8. Frame
9. Trigger Guard
10. Trigger
11. Cylinder Crane
12. Ejector Rod

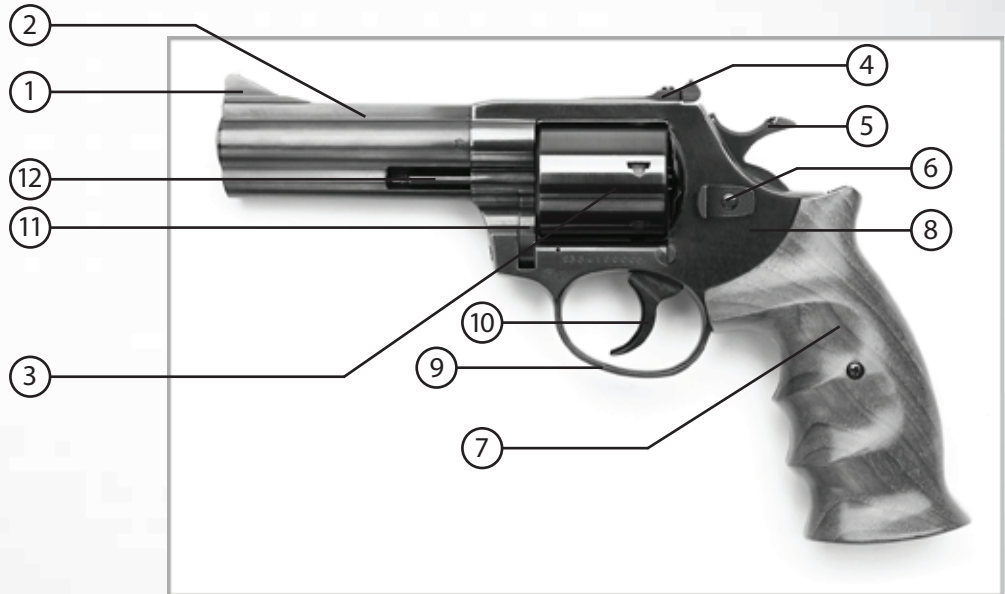

05 | DESCRIPTION OF THE REVOLVER

ACCESORIES

- Nylon brush
- Brass brush
- Sighting-in target
- Operating instructions

SAFETY DESIGN PRECAUTIONS

- The triggering mechanism is blocked, if the cylinder is open or if it has not fully returned to basic position.
- The cylinder cannot be open, if the hammer is cocked.
- The in-built automatic safety prevents release in case the weapon falls down, in case the finger involuntarily slips from the trigger or from the hammer (if it is tensioned by hand).

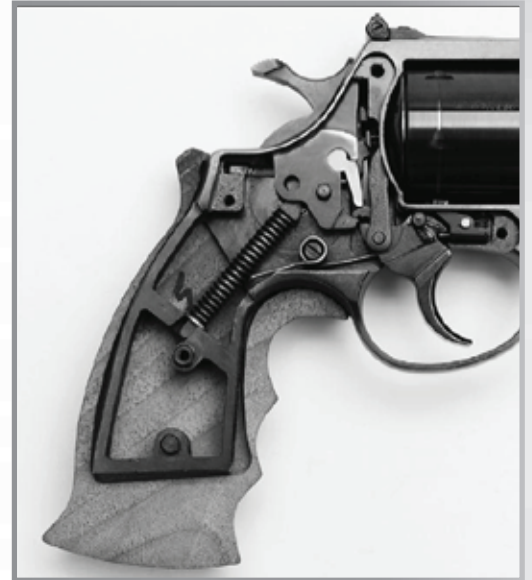

RIA STEEL/STAINLESS REVOLVER TECH SPECS

| MODEL | CALIBER | BARREL LENGTH | REVOLVER LENGTH | REVOLVER HEIGHT | REVOLVER WIDTH | MASS | LENGTH OF AIMING LINE | CARTIDGES IN CYLINDER | BACK SIGHT |
|-------|--------------|---------------|-----------------|-----------------|----------------|-----------|-----------------------|-----------------------|------------|
| 3520 | .357 Magnum | 2" | 8" | 6" | 6" | 1.87 lbs. | 4" | 6 | Fixed |
| 3530 | .357 Magnum | 3" | 9" | 6" | 6" | 1.96 lbs. | 5" | 6 | Fixed |
| 3531 | .357 Magnum | 3" | 9" | 6" | 6" | 1.98 lbs. | 5" | 6 | Adjustable |
| 3541 | .357 Magnum | 4" | 10" | 6" | 6" | 2.2 lbs. | 6" | 6 | Adjustable |
| 3561 | .357 Magnum | 6" | 12" | 6" | 6" | 2.54 lbs. | 8" | 6 | Adjustable |
| 3820 | .38 Special | 2" | 8" | 6" | 6" | 1.87 lbs. | 4" | 6 | Fixed |
| 3830 | .38 Special | 3" | 9" | 6" | 6" | 1.96 lbs. | 5" | 6 | Fixed |
| 3831 | .38 Special | 3" | 9" | 6" | 6" | 1.98 lbs. | 5" | 6 | Adjustable |
| 3841 | .38 Special | 4" | 10" | 6" | 6" | 2.20 lbs. | 6" | 6 | Adjustable |
| 3861 | .38 Special | 6" | 12" | 6" | 6" | 2.54 lbs. | 8" | 6 | Adjustable |
| 3220 | .32 S&W long | 2" | 8" | 6" | 6" | 1.92 lbs. | 4" | 6 | Fixed |
| 3230 | .32 S&W long | 3" | 9" | 6" | 6" | 2.02 lbs. | 5" | 6 | Fixed |
| 3231 | .32 S&W long | 3" | 9" | 6" | 6" | 2.05 lbs. | 5" | 6 | Adjustable |
| 3241 | .32 S&W long | 4" | 10" | 6" | 6" | 2.27 lbs. | 6" | 6 | Adjustable |
| 3261 | .32 S&W long | 6" | 12" | 6" | 6" | 2.65 lbs. | 8" | 6 | Adjustable |
| 2230 | .22 LR | 3" | 9" | 6" | 6" | 2.20 lbs. | 5" | 9 | Fixed |
| 2231 | .22 LR | 3" | 9" | 6" | 6" | 2.20 lbs. | 5" | 9 | Adjustable |
| 2241 | .22 LR | 4" | 10" | 6" | 6" | 2.43 lbs. | 6" | 9 | Adjustable |
| 2261 | .22 LR | 6" | 12" | 6" | 6" | 2.76 lbs. | 8" | 9 | Adjustable |
| 2330 | .22 WMR | 3" | 9" | 6" | 6" | 2.20 lbs. | 5" | 8 | Fixed |
| 2331 | .22 WMR | 3" | 6" | 6" | 6" | 2.20 lbs. | 5" | 8 | Adjustable |
| 2341 | .22 WMR | 4" | 10" | 6" | 6" | 2.43 lbs. | 6" | 8 | Adjustable |
| 2361 | .22 WMR | 6" | 12" | 6" | 6" | 2.76 lbs. | 8" | 8 | Adjustable |

07 | EXPLODED VIEWS

1. Frame
2. Barrel shroud
3. Barrel
4. Ejector
5. Cylinder
6. Ejector spring
7. Ring
8. Center pin spring
9. Ejector screw
10. Ejector rod
11. Cylinder crane
12. Chasing nut
13. Crane screw
14. Rear sight unit
15. Rear sight screw
16. Screw
17. Thumb piece
18. Bolt
19. Spring
20. Hammer
21. Pin
22. Spring
23. Pin
24. Seal
25. Firing pin nut
26. Firing pin
27. Firing pin spring
28. Washer
29. Screw
30. Grips
31. Main spring pin
32. Main spring
33. Screw
34. Trigger spring
35. Hammer block
36. Trigger
37. Pin
38. Hand
39. Side plate
40. Screw
41. Spring
42. Pin
43. Cylinder stop
44. Pin
45. Pin
46. Pin
47. Spring
48. Spring

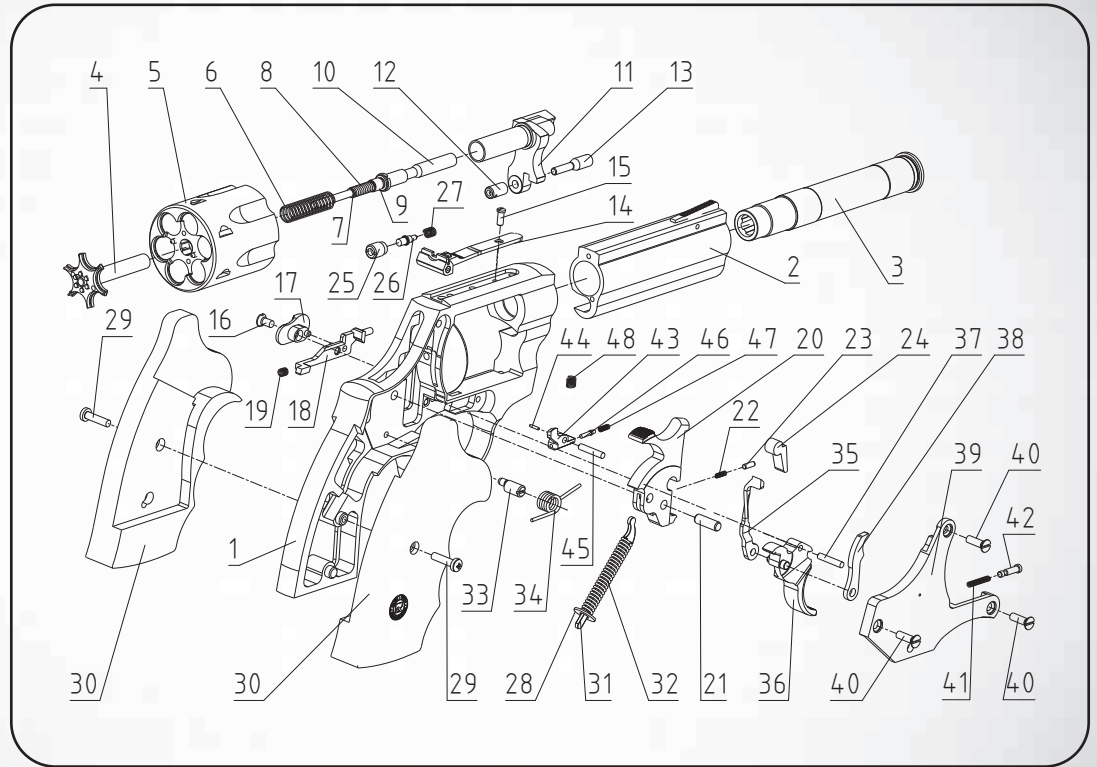

08 | AMMUNITION

This revolver is intended for self-defense, sport shooting or service use. Exclusively recommended factory loaded ammunition of the caliber marked on the weapon may be used, see following table:

| MODEL | AMMUNITION |
|-----------------------------------|-------------------------------------------|
| Revolver Cal. .22 LR (Long Rifle) | .22 LR (Long Rifle) |
| Revolver Cal. .22 WMR | .22 WMR (.22 Magnum, .22 Win Mag.R.F.) |
| Revolver Cal. .32 S&W long | .32 S&W long |
| Revolver Cal. .38 Special | .38 Special |
| Revolver cal. .357 Magnum | .357 Magnum |

NOTE: Always use the recommended original ammunition. Producer will not assume responsibility on any damages and/or personal injury caused by the use of ammunition that is not indicated on the weapon barrel.

09 | OPERATING INSTRUCTIONS



LOADING

Always aim with the weapon away from the body and downwards. Push the thumb piece at the left-hand side of the frame forward and at the same time push the cylinder from the right to the left, until it opens. The open cylinder is freely pivotable. Shift the cartridges into the chambers and return the cylinder. Never knock at the cylinder, as you could damage

the crane. The weapon is now loaded and prepared for shooting.



UNLOADING

Open the cylinder in the same way as for the loading operation. When the cylinder is open, push onto the shaft of the extractor. This enables you to get all cartridges out of the cylinder.



ADJUSTING SIGHTS

(For models with adjustable rear sight only)

The setting can be done easily with a screwdriver. Turning the setting

screw at the upper side of the rear sight clockwise makes the point of hit move up. Turning the setting screw counter-clockwise makes the point of hit move down. If you lift the sight, the central point of the hits gets lifted, if you lower the sight, the central point of the hits gets lowered.



AIMING

Align the front sight and the rear sight so as to allow the upper edge of the front sight to be aligned with the upper edge of the rear sight, the front sight being in the centre

of the sighting notch. You should see the target at the upper edge of the front sight.



ADJUSTING OF TRIGGER STRENGTH

First of all unscrew the grip plate screw and remove the right side grip plate. Thereby a hole with eccentric pin is opened in the revolver cover. By means of a screwdriver you can turn the eccentric pin and by this means adjust the strength of the trigger spring. To lower the trigger strength turn in that direction, in which the arm of the trigger spring

(protruding on the left-hand side under the cover) is turned downwards. To increase the trigger strength turn in that direction, in which the arm of the trigger spring is turned upwards.



SHOOTING

Shooting single action:

Cock the hammer backward with the thumb of the

shooting hand, until the trigger snaps. The gun will fire by soft pull of the trigger.



DECOCKING THE HAMMER

If the revolver is set for shooting in single action mode with hammer

cocked, and the shooter decides not to shoot, the hammer must be decocked to its original position, in order to make the arm safe. First of all aim to a secure direction. Then use your thumb firmly pressing onto the serration part of the hammer and carefully pull the trigger with your forefinger only enough to release the hammer. Then, keeping the pressure of the thumb on the hammer, return it slowly and carefully to its original position. Release the trigger.



CAUTION:

THE CYLINDER SHOULD NOT BE SWUNG IN AND OUT OF THE FRAME WITH EXCESSIVE FORCE, AND NEVER BY WRIST ACTION.

10 | MAINTENANCE

CLEANING THE GUN

ATTENTION:

1. Make sure the revolver is unloaded prior to cleaning!
2. Clean immediately after the shooting (even if you may have given only one shot). After a series of shots (e.g. in case of sport shooting), clean the weapon thoroughly after every 50 shots and let the weapon cool down with opened cylinder for at least 10 minutes.
3. In current cases there is no need to dismantle the revolver for cleaning. If dismantling appears to be necessary for cleaning, please have it made by the manufacturer or an authorised gunsmith.
4. Open the cylinder and clean the revolver with a brush, with pieces of cloth and gun oil, very thoroughly in all places for removing products of shooting and layers of cartridge particles.
5. If the barrel bore, the cartridge chambers and the cylinder front bear only slight signs of impurities, the nylon brush and oiled cloth pieces will do for cleaning.
6. If the soiling is strong, cover the dirty spots with a thick layer of gun oil with a brush and leave it for about 10 minutes, then remove the gunpowder and lead with a brass brush, continue with oiled nylon brush and rub dry with pieces of cloth. Repeat this procedure, until the last piece of cloth is clean.
7. Take care when cleaning, you may damage the barrel bore and the muzzle.
8. No vaseline, organic oil or grease may be used for lubrication and preservation.
9. If you intend to leave the revolver for a longer time without operating it, preserve it with gun oil.
10. Keep the weapon in dry environment with steady temperature, to prevent bedewing of the revolver that can result in corrosion.
11. Do not dismantle the weapon (except for replacing the grip plates) and do not repair it by yourselves, either; any repairs should be made by the manufacturer or by a trade mark repair shop. If these instructions are not observed, the manufacturer will not acknowledge the guarantee period.



CAUTION:

NEVER STORE THE REVOLVER WITH A PLUG IN THE BARREL. THIS WILL CONTRIBUTE TO ACCUMULATION OF MOISTURE. THE GUN SHOULD BE RE-STORED IN ROOMS WITH DRY ATMOSPHERE AND WITH THE LEAST HUMIDITY. IT SHOULD NOT BE STORED ENCASED IN LEATHER OR ANYTHING THAT WILL ATTRACT AND HOLD MOISTURE, CAUSING IT TO RUST.



SCAN QR

SEE FULL VIDEO TUTORIALS ON OUR
WEBSITE

REVOLVER MAINTENANCE



ATTENTION:

THIS WEAPON HAS BEEN COMPLETELY CHECKED AND TESTED BY ZEROING. PLEASE CONTACT THE DEALER IN YOUR REGION IN CASE ANY TECHNICAL PROBLEM MAY APPEAR.



WARNING:

ALL WEAPONS REQUIRE REGULAR UPKEEP AND MAINTENANCE THAT MAY RESULT IN THE NECESSITY OF ADJUSTMENT OR REPAIR. HAVE YOUR WEAPON CHECKED BY A GOOD SERVICE TECHNICIAN EVERY YEAR, ALTHOUGH YOU MAY HAVE THE IMPRESSION THAT IT OPERATES WELL, SINCE DAMAGE, IMPROPER FUNCTION OR CORROSION OF SOME PARTS MAY NOT BE REVEALED DURING CURRENT EXTERNAL CHECK UP. IF YOU FIND ANY MECHANICAL FAILURE, DO NOT CONTINUE TO USE THE WEAPON. UNLOAD IT AND HAVE IT THOROUGHLY EXAMINED BY A RELIABLE GUNSMITH/REPAIR SHOP. ALSO IF SOME WATER, SAND, OR ANOTHER ALIEN MATERIAL MAY HAVE GOT INTO THE WEAPON, CLEAN THE SAME VERY THOROUGHLY. IF THE WEAPON IS NOT KEPT CLEAN AND IN CORRECT WORKING CONDITION, DANGEROUS SITUATIONS AND ACCIDENTS WITH SERIOUS PHYSICAL INJURY OR MATERIAL LOSS MAY OCCUR.

STORAGE AND TRANSPORTATION

When storing the firearm and ammunition, store in separate locations, store ammo in a cool, dry location.

When storing the gun for a prolonged period of time, it is necessary to oil it heavily with an acid-free lubricant. The external parts must be coated with an anti-rust oil or grease to prevent moisture causing the parts to rust and malfunction. Before usage, the revolver must be cleaned and wiped dry again as discussed previously.

WARNING:

CHILDREN ARE ATTRACTED TO AND CAN OPERATE FIREARMS THAT CAN CAUSE SEVERE INJURIES OR DEATH. PREVENT CHILD ACCESS BY ALWAYS KEEPING FIREARMS LOCKED AWAY AND UNLOADED WHEN NOT IN USE. IF YOU KEEP A LOADED FIREARM WHERE A CHILD OBTAINS AND IMPROPERLY USES IT, YOU MAY BE FINED OR SENT TO PRISON.

WARNING:

THE FIREARM SHOULD BE RE-STORED IN ROOMS WITH A DRY ATMOSPHERE AND WITH THE LEAST HUMIDITY. IT SHOULD NOT BE STORED ENCASED IN LEATHER OR ANYTHING THAT WILL ATTRACT AND HOLD MOISTURE, CAUSING IT TO RUST.

ORDERING PARTS

Visit RIA website to browse, learn more about and purchase parts and ammunition for all of your Rock Island Armory products.

 www.advancedtactical.com



WARRANTY REGISTRATION

Armcor's warranty covers its firearms and parts. We offer limited lifetime warranty on our products for their intended purpose. As with any product, abuse, gunsmithing by an unqualified person and normal wear and tear are excluded. Additionally, if the firearm was modified and/or repaired by an unqualified gunsmith without permission from Armcor, then the warranty will be void. If warranty work should be required, return the firearm to the address listed below. There is no refund for the shipping cost. Gunsmithing services are available by registered Armcor Gunsmithers. Please email the address below.

To register your firearm, please go to www.rockislandarmory.com/support-center/warranty/ and complete online warranty form. In comments section, write warranty registration and press submit. You can also go to www.rockislandarmory.com and press warranty section at the bottom.

For more information on warranty, visit www.rockislandarmory.com, or email support@armcor.com

Armcor Precision International
150 North Smart Way
Pahrump, NV 89060
Email: support@armcor.com

IMPORTANT WARRANTY INFORMATION

Our Rock Island Army revolvers are warranted to function only with Factory FMJ Brass Cased Ammo and the Original Factory Magazine. Use of Handloads is not covered in Warranty of Repair for the function of the Firearm.

DUE TO THE FIT AND TIGHTNESS OF FIREARM, RIA RECOMMENDS A BREAK-IN PERIOD OF 500 ROUNDS.

THIS IS HOW YOU VOID YOUR WARRANTY

- * Refinishing your RIA firearm
- * Misuse, Mishandling, Dropping your RIA Firearm
- * Firing Remanufactured or Reloaded Ammunition
- * Not properly reassembling your RIA Firearm resulting in damage, ie reverse plugs!
- * Any addition of after market parts
- * Unauthorized repairs done by any other than Rock Island Army

LIMITS ON WARRANTY (will not cover)

- * Finish, Holster wear, Scratches, Chemical damage
- * After Market Magazines
- * Damage to Factory Magazines
- * Sights not installed by Rock Island Army
- * Recoil Springs

WE RESERVE THE RIGHT TO CHARGE FOR LABOR, PARTS AND SHIPPING TO RETURN YOUR RIA FIREARM
BACK TO FACTORY SPECIFICATIONS IF IT HAS BEEN ALTERED.

NOTES

NOTES



WWW.ROCKISLANDARMORY.COM

